

1.

1.1

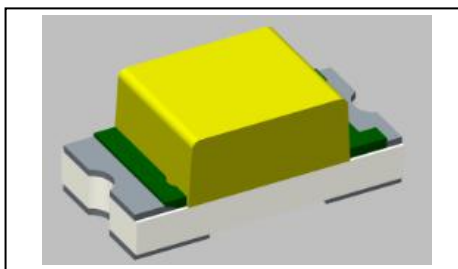

1.2



1.3

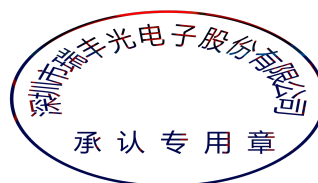

1.4

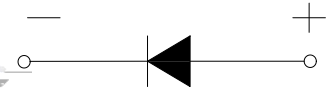
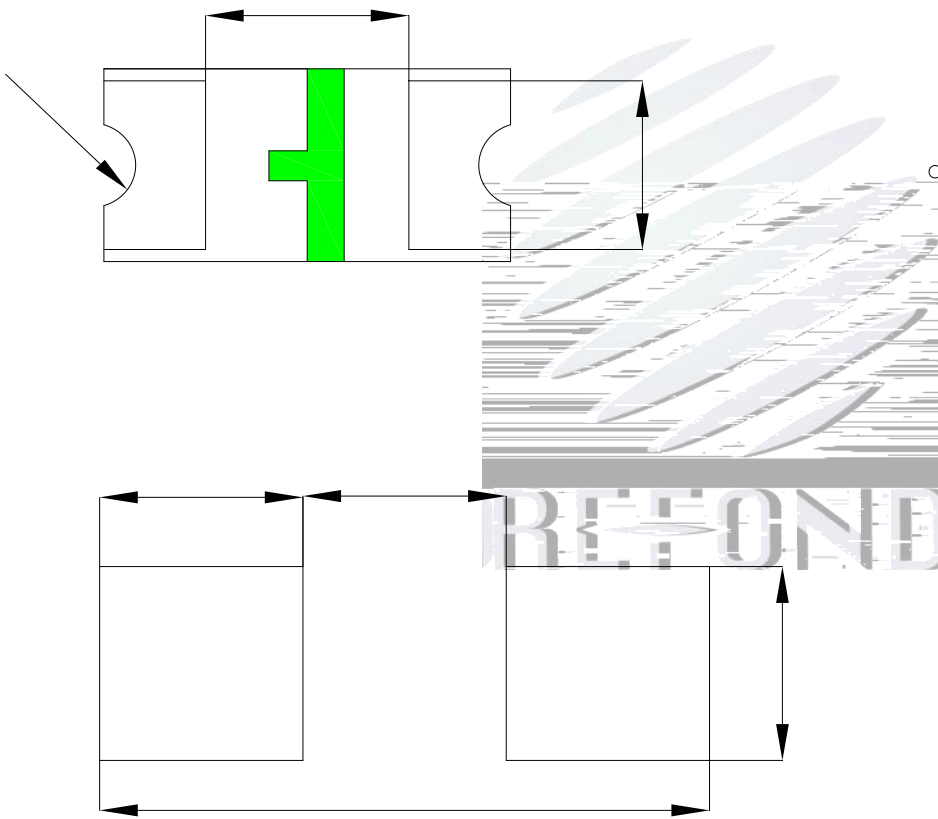
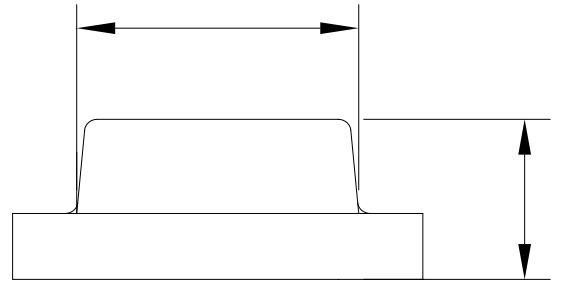
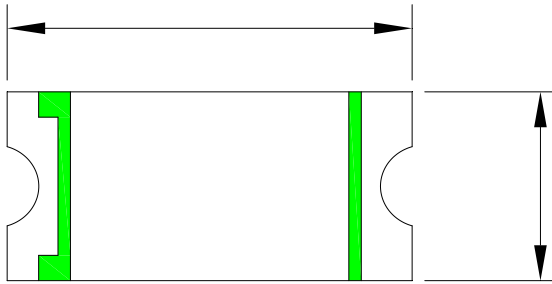

±

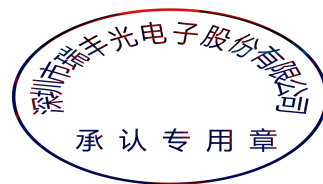

1.5

							μ

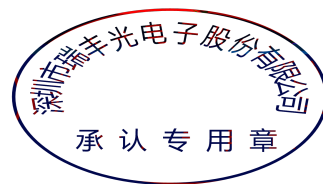
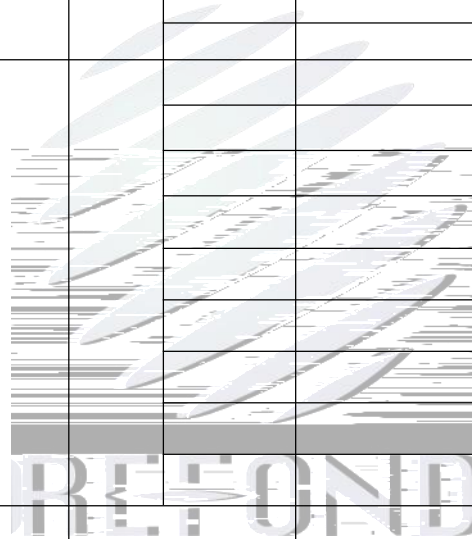



1.

(20)

(20)

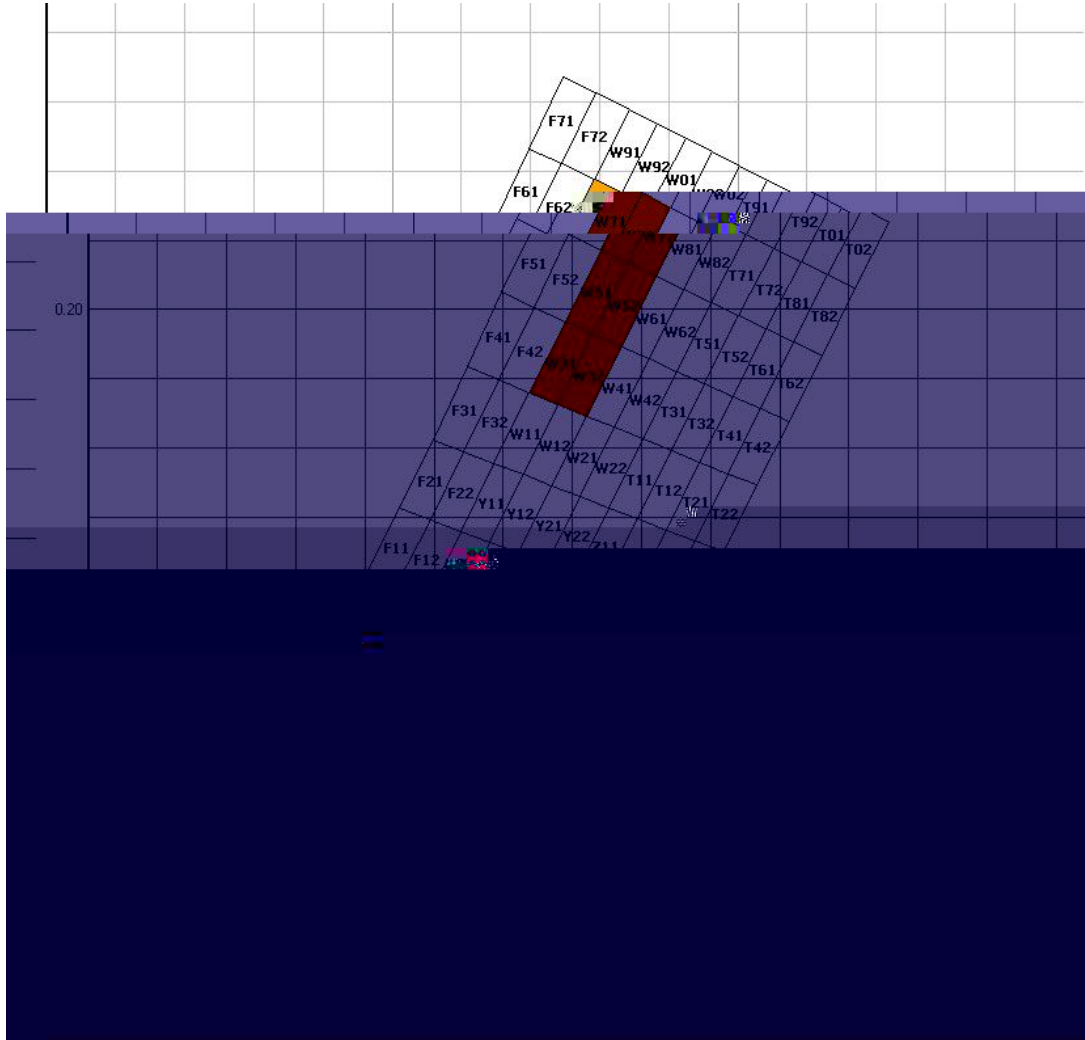

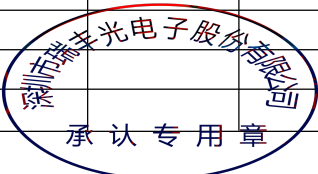



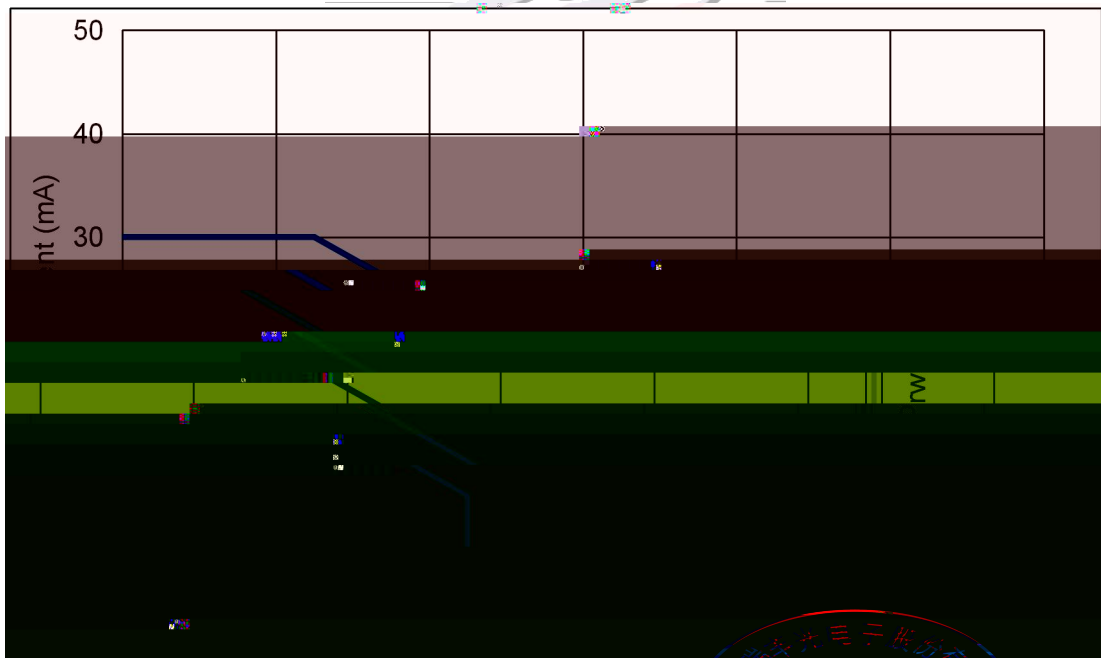
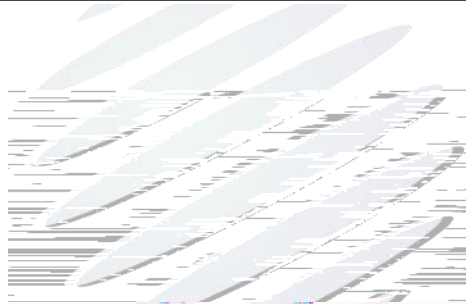
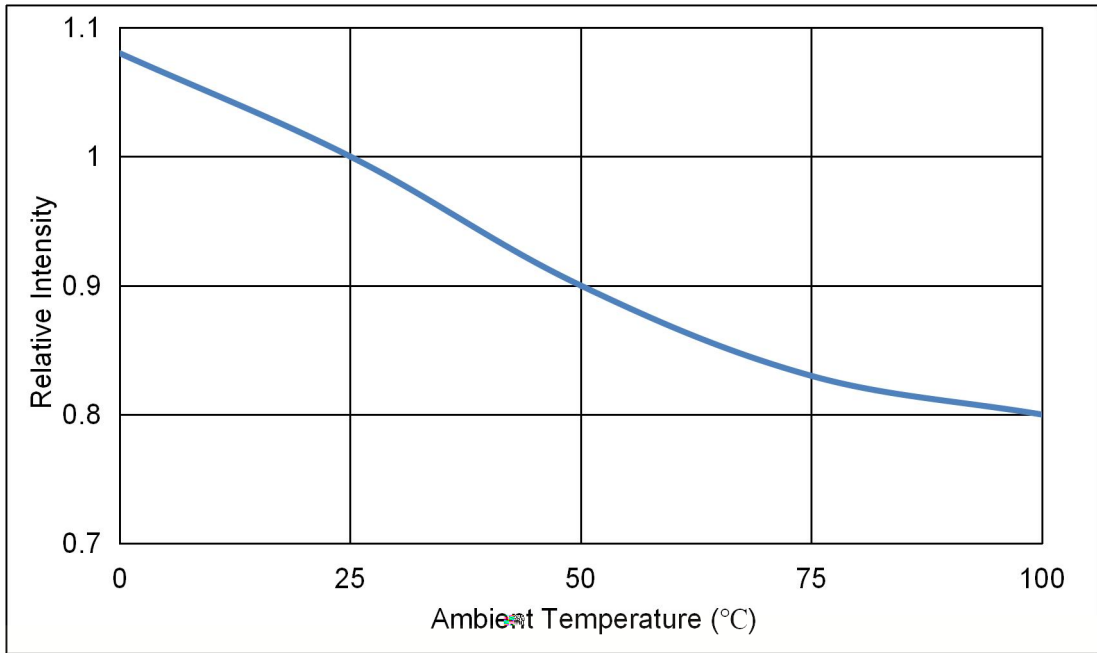

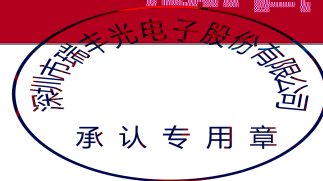
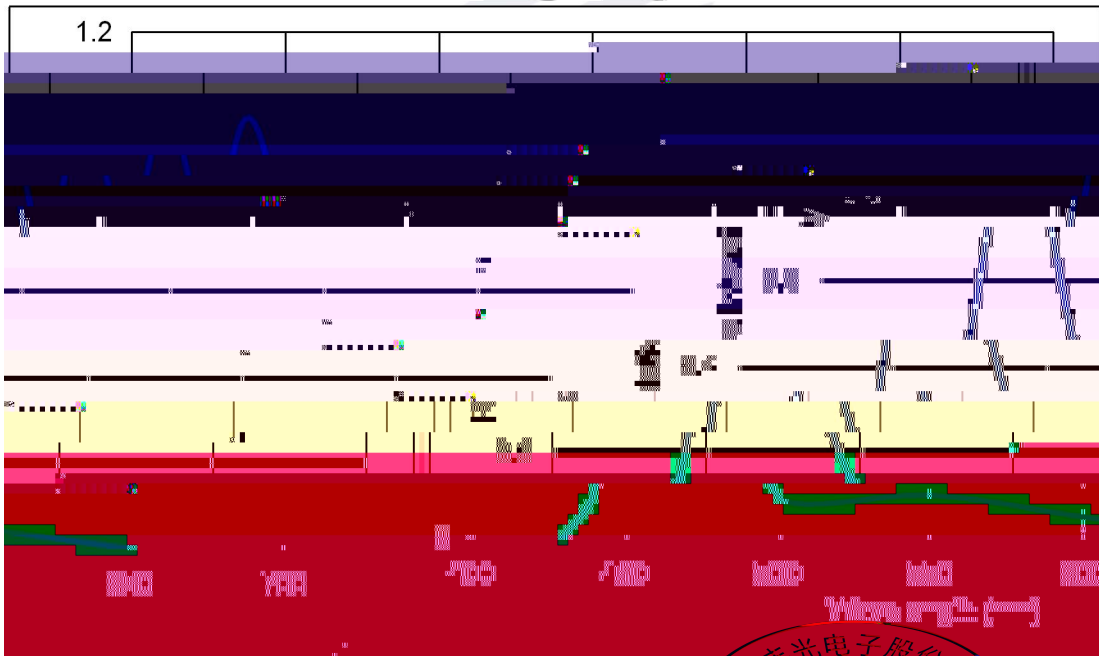
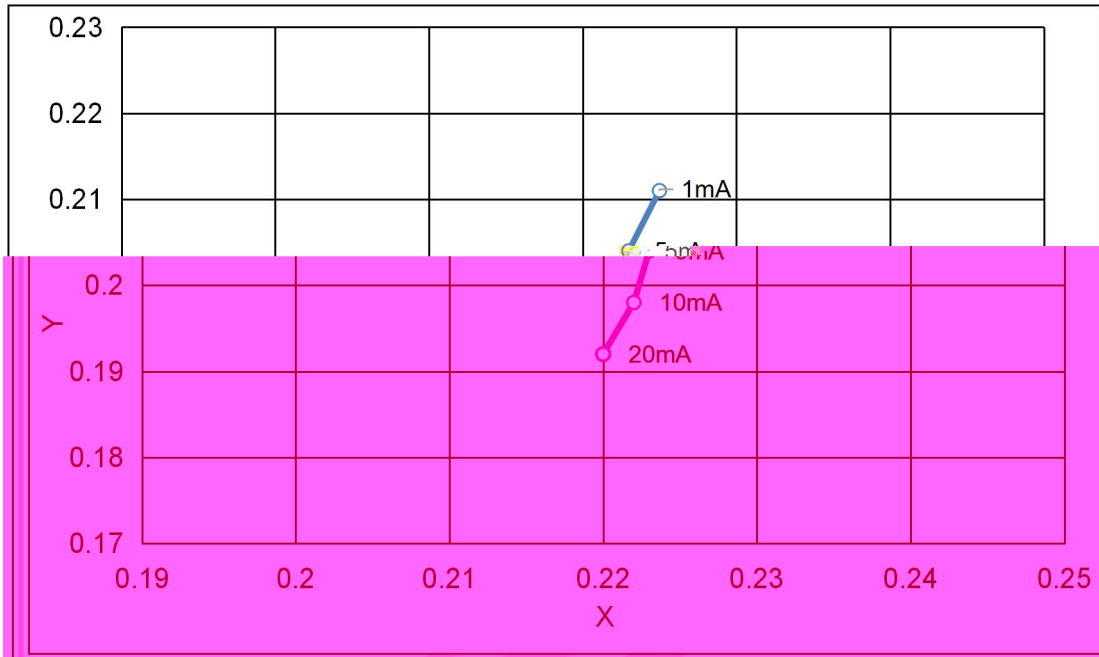

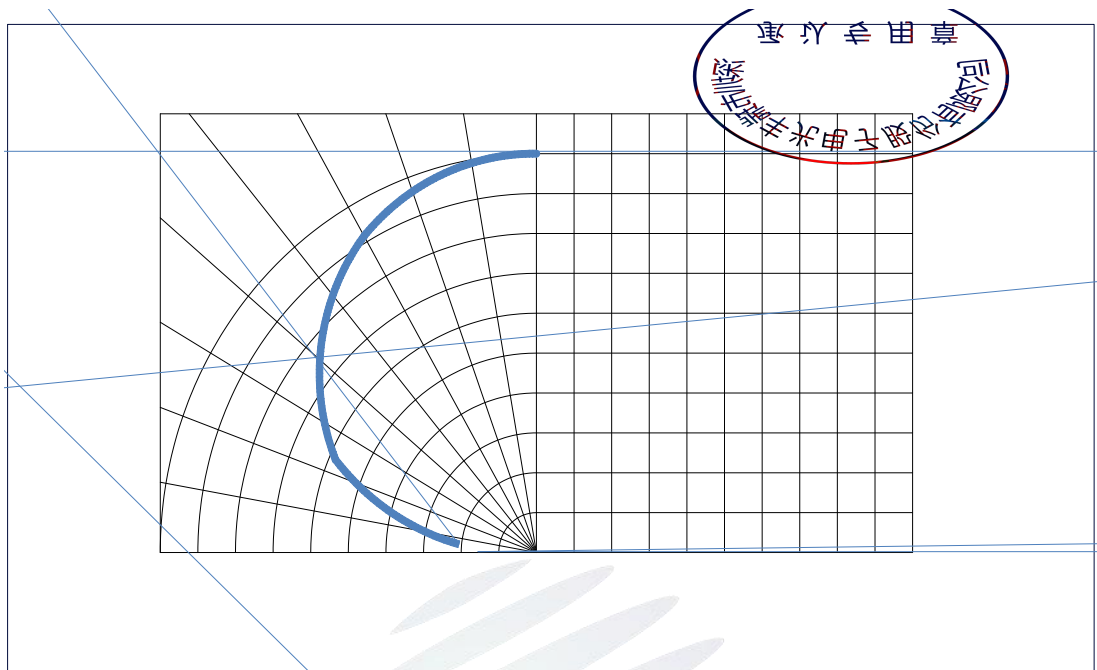

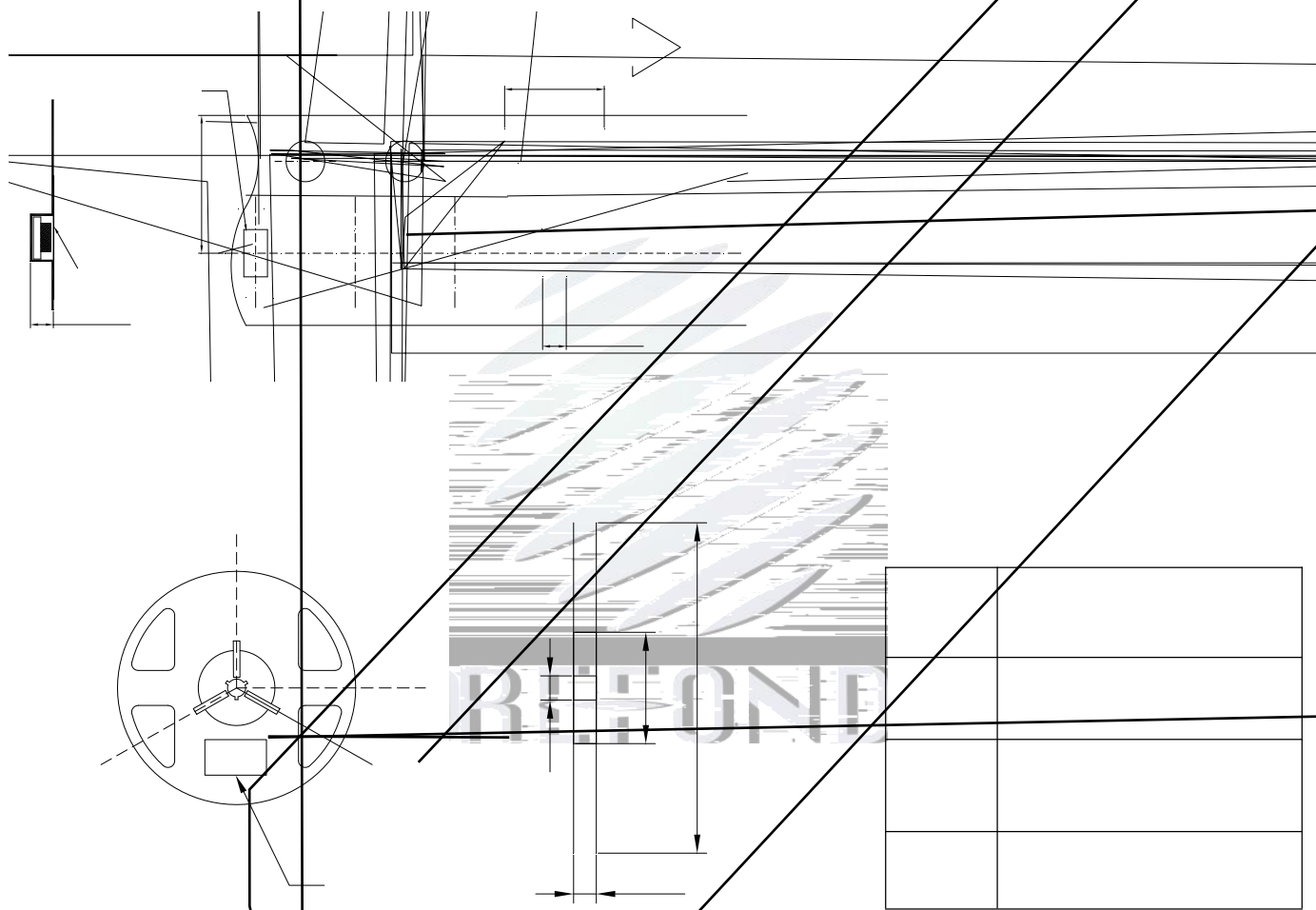

2.

2.1



PART NO:		
SPEC NO:		
LOT NO		
BIN CODE:		
Φ:	XY:	
VF:	WLD:	
	QTY:	
	DATE:	

2.2

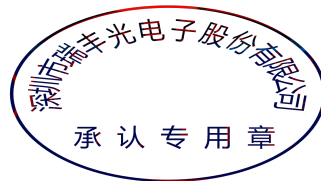
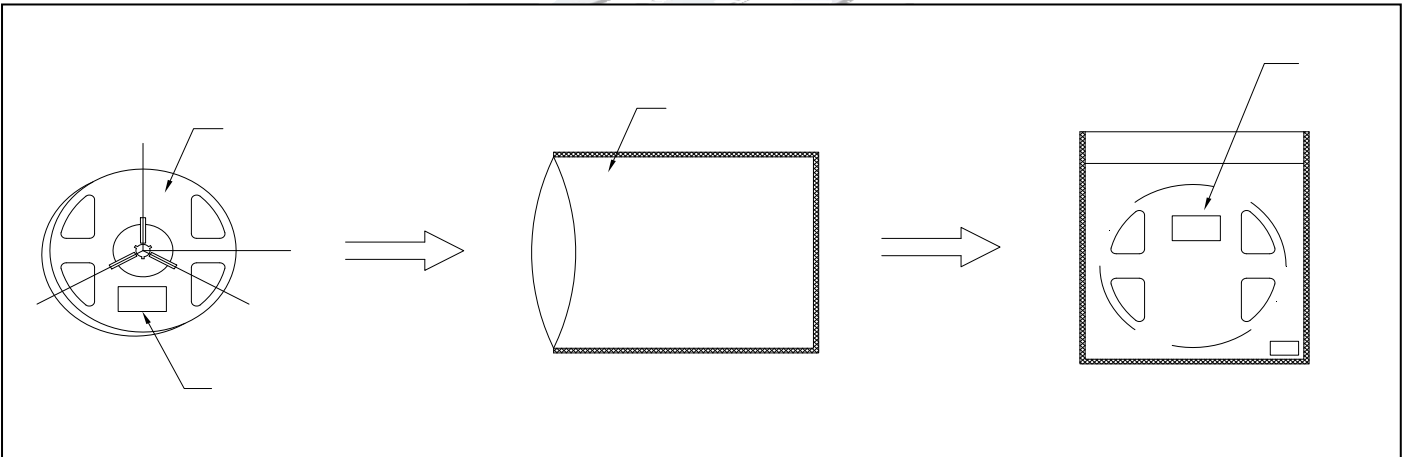

2.3

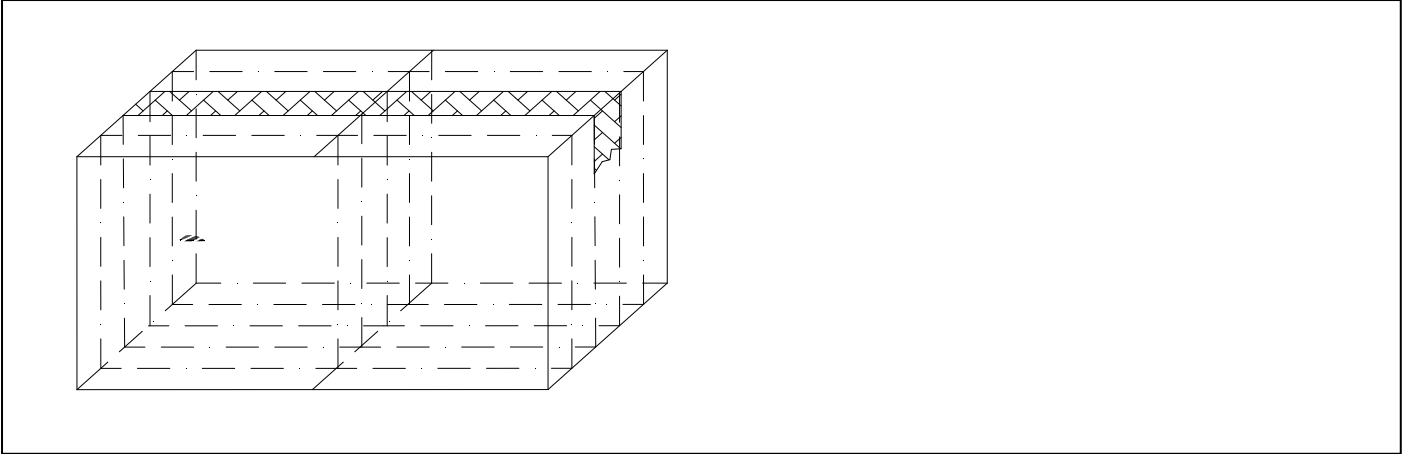

2.4



2.5

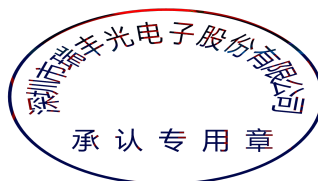

3.

3.1



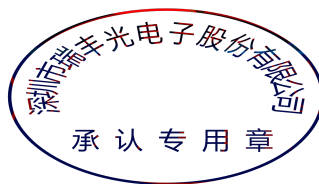

4.

4.1

